

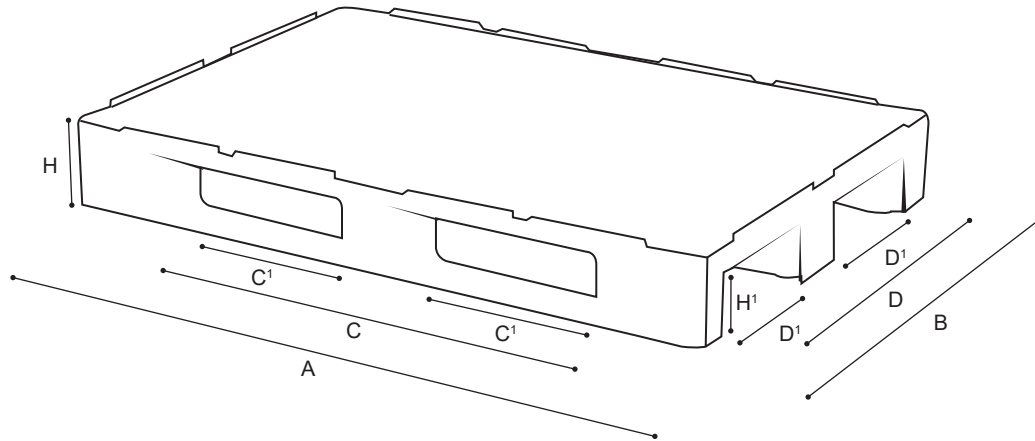

**PALLET / LOGISTICS AND HANDLING**

**My-I HYGIENIC PALLET 800x1200  
HEAVY PAYLOADS**



The My-I Hygienic Pallet is used in the food, chemical and pharmaceutical industry, representing the ideal solution for logistics, storage and handling in light and heavy manufacturing.

Injection molded in food-grade High-Density Polyethylene (HDPE) is guaranteed and certified for foodstuff, it is recyclable, washable and available in the version with or without metal reinforcement bars.

This pallet, being fully closed and sealed, shows no weight variations due to water contact, and is also particularly resistant to U.V. and infrared rays, high and low temperatures, acids and alkalis.

**Static Capacity:** 5000 Kg (The capacity is valid for filmed charge equally distributed on the pallet surface).

**Dynamic Capacity:** 1500 Kg (The capacity is valid for filmed charge equally distributed on the pallet surface).

**Capacity on RACK:** 500 Kg (The capacity is valid for filmed charge equally distributed on the pallet surface).

900 Kg With metal reinforcement bars  
(The capacity is valid for filmed charge equally distributed on the pallet surface).

**Weight:** 16 Kg

**Color:**  Food Contact Neutral

**Material:**   **HDPE** Inert to acids, hydrocarbons and solvents.

**Size**

ARTICLE	EXTERNAL SIZE mm							
	A	B	H	H'	C	C'	D	D'
MY-I HYGIENIC PALLET 800x1200	1200	800	165	95	795	325	600	227

The sales office is at your disposal to advise the version most suited to your needs.